

Extra Large Syringe Barrel - 140 cc

The 140 cc syringe barrel is the largest sized syringe barrel available in the fluid dispensing market, allowing production to run longer with fewer fluid changeovers. It holds more dispensed fluids than the other sizes, including 3 cc, 5 cc, 10 cc, 30 cc, 55 cc and 70 cc. It is ideal for electronic applications such as bonding, underfill, potting, and conformal coating. It is compatible with most dispensing material such as adhesives, epoxies, sealants, solder pastes, and more...

The barrel design with consistent internal diameter maintains the proper seal with the piston for optimal dispensing results.

All syringe barrels are manufactured in Techcon's silicone-free facilities in the United States and certified for industrial use. Air adapter is connected directly to the syringe without a retainer.

FEATURES:

- Made from clear Polypropylene
- Ultra-low draft construction of inner diameter
- High accuracy and stability
- Silicon and chloride-free
- Connect directly to air adapters
- Allows for longer production runs, reduces downtime



Extra Large Syringe Barrel - 140 cc Data Sheet



SPECIFICATIONS:

Volume	140 cc (4.73 oz)
Material	Clear Polypropylene
Length	177 mm (6.969")
Outside Diameter (O.D.)	40 mm (1.57")
Outlet port	Male Luer Lock
Maximum Pressure	100 psi

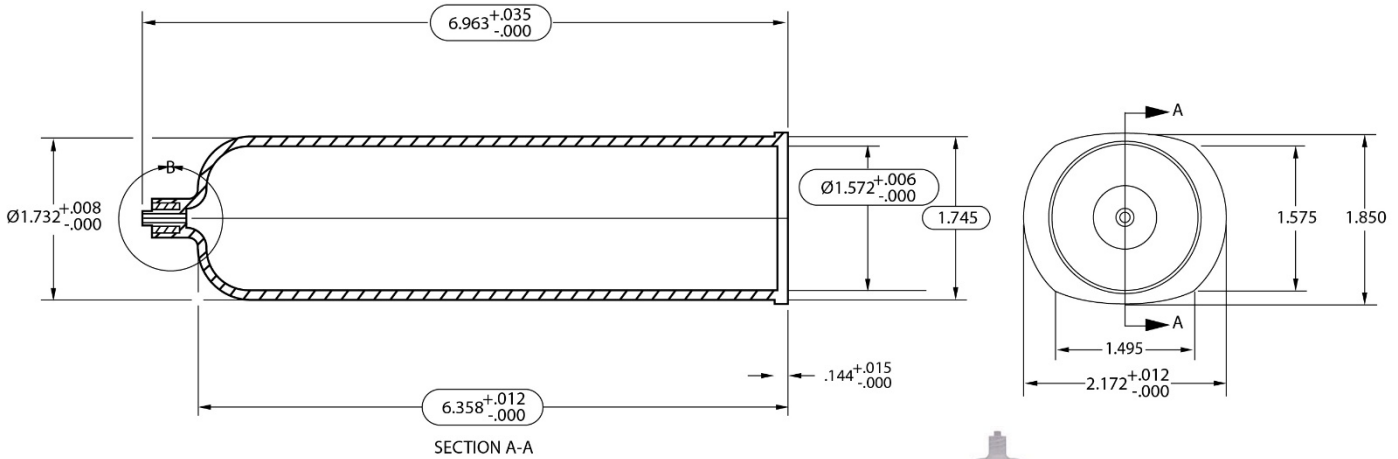

PART NUMBERS:

TS60C-LL-N-250	1	Syringe, 140 cc (QTY = 250)
TS5C-A-500	2	End Cap For 140 cc Syringe (QTY = 500)
TS7P-LL-500	3	Luer lock tip cap (QTY = 500)
TS4P-LL-500	4	Piston For 140 cc Syringe (QTY = 500)
RH60CC-LL-6	5	Receiver Head w/ 6' hose for TS60C-LL-N