

Botron SpeedLane Technical Data Sheet



Features:

Botron's SpeedLane with our built-in ESD "ELITE Data Logger System". Built with 304 Stainless Steel for long life. Sold in pairs (2) or sets. Each Flip Lane has a total of six optical sensors which will stop any unauthorized personnel from entering without first passing the test. The Flip wings are made of clear acrylic and can be backlit with LED lights. Exit switch for easy return.

PROPERTIES

SPECIFICATIONS

Material:	304 Stainless Steel
Optical Sensors:	6
HID:	Yes
Power:	110V
Output:	24VDC
Current:	10mA
Drive Motor:	DC20V/100w
Size:	47.8" x 11.8" x 39.4"
Alarm Outputs:	Yes
Configurations:	Single or Multiple Lane

PART NUMBERS

- B88037** ELITE Flip Gate (L&R) HID Access Control System
- B88038** ELITE Flip Gate (Center) HID Access Control System

Product Notes and Features

- Arrow Control for Direction Control
- Safety Barrier Wings will open upon loss of power
- Optical Sensors detect Tail-Gaiting
- Corporate Logos can be etched in acrylic panels



Production Automation Corporation | www.gotopac.com | 888.903.0333 | info@gotopac.com

Disclaimer. All statements of technical information are believed to be true and are based upon tests we believe to be reliable. The proper use and application for this product must be the responsibility of the user. The statements herein shall have no force or effect.

CLOSEUPS

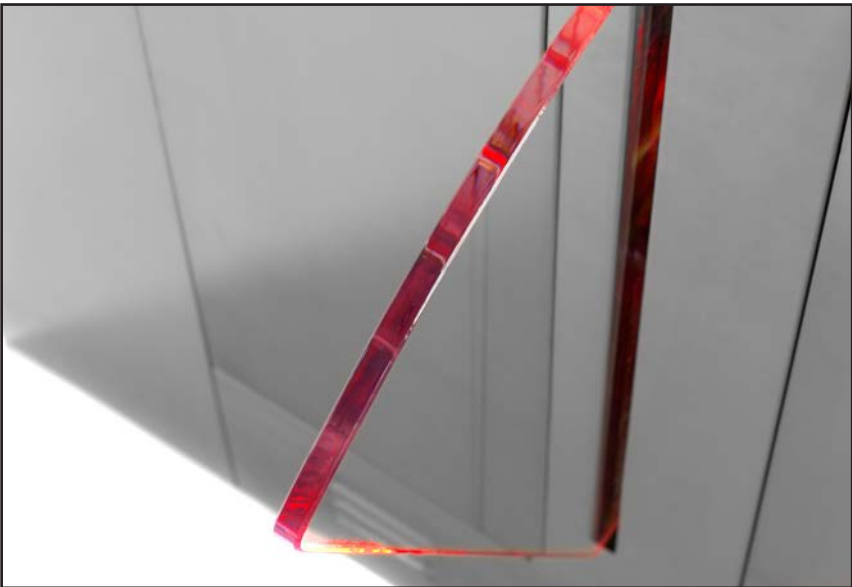

DIMENSIONS

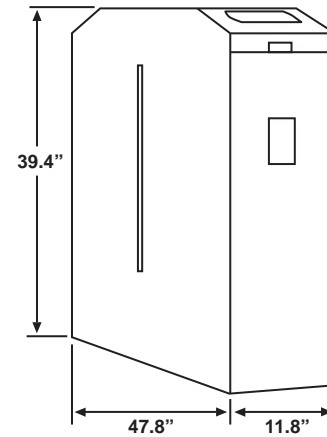
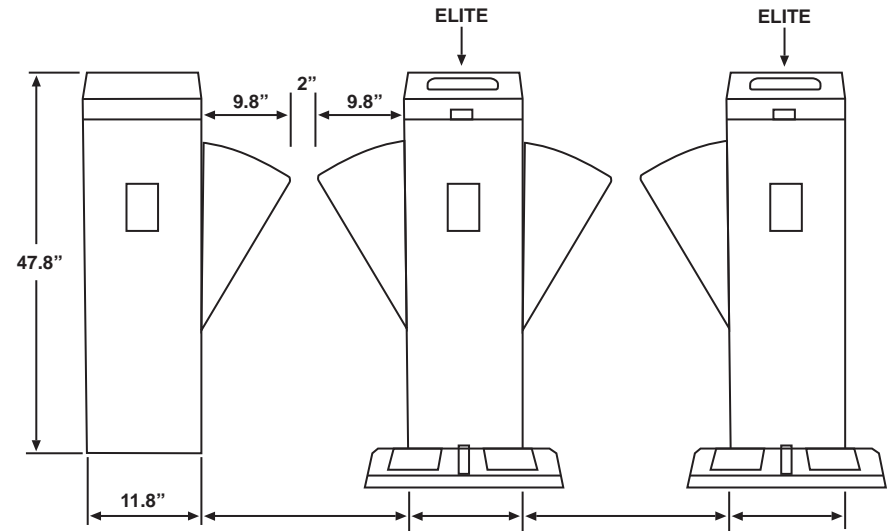

Production Automation Corporation | www.gotopac.com | 888.903.0333 | info@gotopac.com

Disclaimer. All statements of technical information are believed to be true and are based upon tests we believe to be reliable. The proper use and application for this product must be the responsibility of the user. The statements herein shall have no force or effect.